



Average Current Mode PWM Controller

FEATURES

- Practical Primary Side Control of Isolated Power Supplies with DC Control of Secondary Side Current
- Accurate Programmable Maximum Duty Cycle Clamp
- Maximum Volt-Second Product Clamp to Prevent Core Saturation
- Practical Operation Up to 1MHz
- High Current (2A Pk) Totem Pole Output Driver
- Wide Bandwidth (8MHz) Current Error Amplifier
- Under Voltage Lockout Monitors VCC, VIN and VREF
- Output Active Low During UVLO
- Low Startup Current (500µA)
- Precision 5V Reference (1%)

BLOCK DIAGRAM

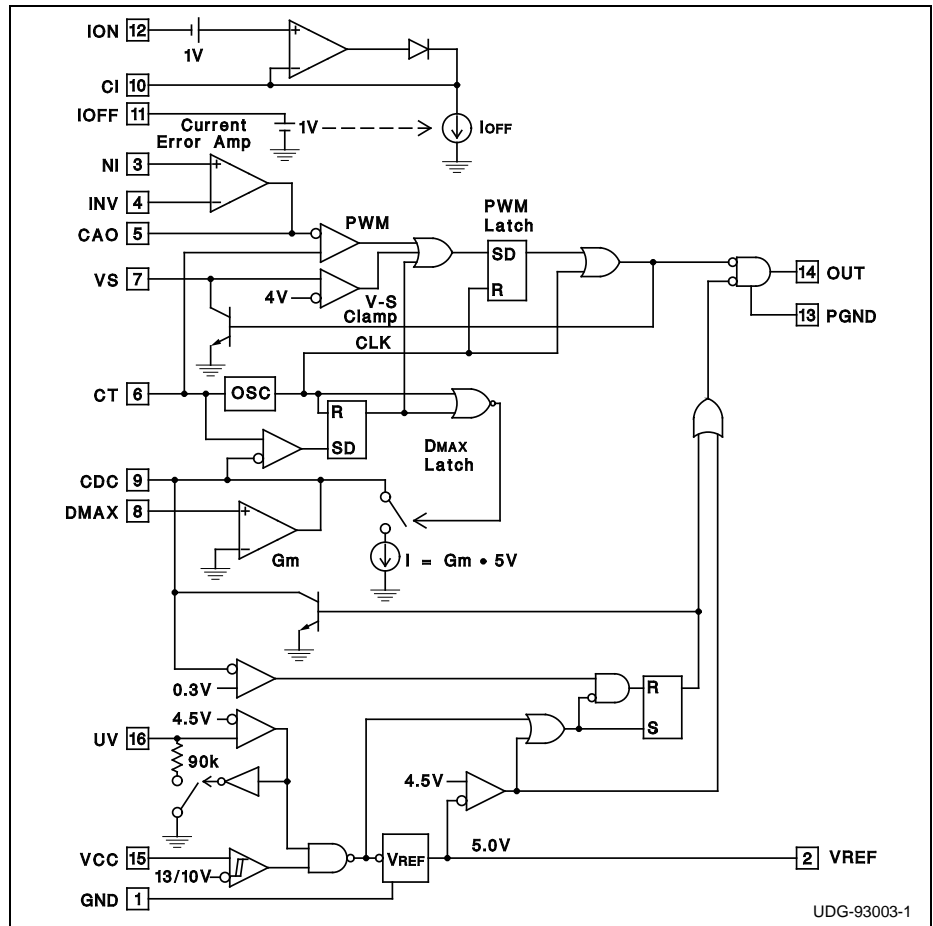

DESCRIPTION

The UC1848 family of PWM control ICs makes primary side average current mode control practical for isolated switching converters. Average current mode control insures that both cycle by cycle peak switch current and maximum average inductor current are well defined and will not run away in a short circuit situation. The UC1848 can be used to control a wide variety of converter topologies.

In addition to the basic functions required for pulse width modulation, the UC1848 implements a patented technique of sensing secondary current in an isolated buck derived converter from the primary side. A Current Waveform Synthesizer monitors switch current and simulates the inductor current down slope so that the complete current waveform can be constructed on the primary side without actual secondary side measurement. This information on the primary side allows for full DC control of output current.

The UC1848 circuitry includes a precision reference, a wide bandwidth Error Amplifier for average current control, an Oscillator to generate the system clock, latching PWM comparator and logic circuits, and a high current Output Driver. The Current Error Amplifier easily interfaces with an

optoisolator from a secondary side voltage sensing circuit.

A full featured Under Voltage Lockout (UVLO) circuit is contained in the UC1848. UVLO monitors the supply voltage to the controller (VCC), the reference voltage (VREF), and the input line voltage (VIN). All three must be good before soft start commences. If either VCC or VIN is low, the supply current required by the chip is only 500µA and the output is actively held low.

Two on board protection features set controlled limits to prevent transformer core saturation. Input voltage is monitored and pulse width is constrained to limit the maximum volt-second product applied to the transformer. A unique patented technique limits maximum duty cycle within 3% of a user programmed value.

These two features allow for more optimal use of transformers and switches, resulting in reduced system size and cost.

Both patents embodied in the UC1848 belong to Lambda Electronics Incorporated and are licensed for use in applications employing these devices.

ABSOLUTE MAXIMUM RATINGS

Supply Voltage (Pin 15)	22V
Output Current, Source or Sink (Pin 14)	
DC	0.5A
Pulse (0.5μs)	2.2A
Power Ground to Ground (Pin 1 to Pin 13)	±0.2V
Analog Input Voltages	
(Pins 3, 4, 7, 8, 12, 16)	-0.3 to 7V
Analog Input Currents, Source or Sink	
(Pins 3, 4, 7, 8, 11, 12, 16)	1mA

Analog Output Currents, Source or Sink (Pins 5 & 10) . . .	5mA
Power Dissipation at TA = 60°C	1W
Storage Temperature Range	-65°C to +150°C
Lead Temperature (Soldering 10 seconds)	+300°C

Notes: All voltages are with respect to ground (DIL and SOIC pin 1). Currents are positive into the specified terminal. Pin numbers refer to the 16 pin DIL and SOIC packages. Consult Packaging Section of Databook for thermal limitations and considerations of packages.

CONNECTION DIAGRAMS

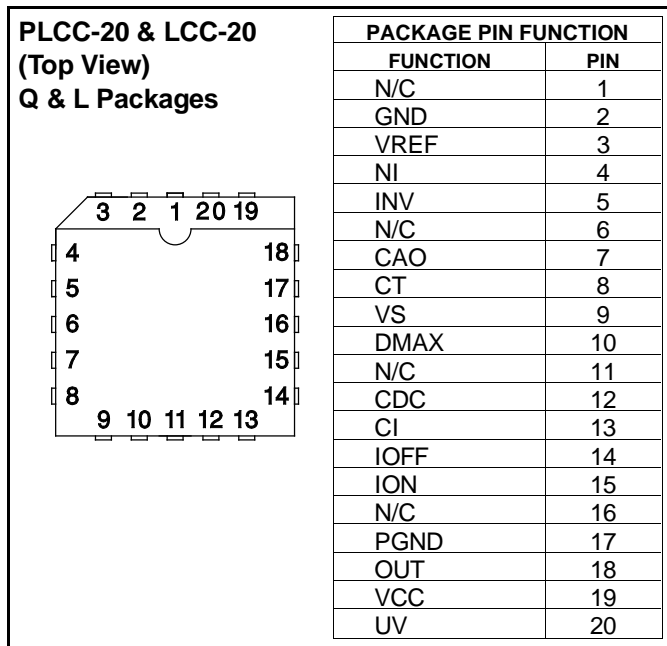
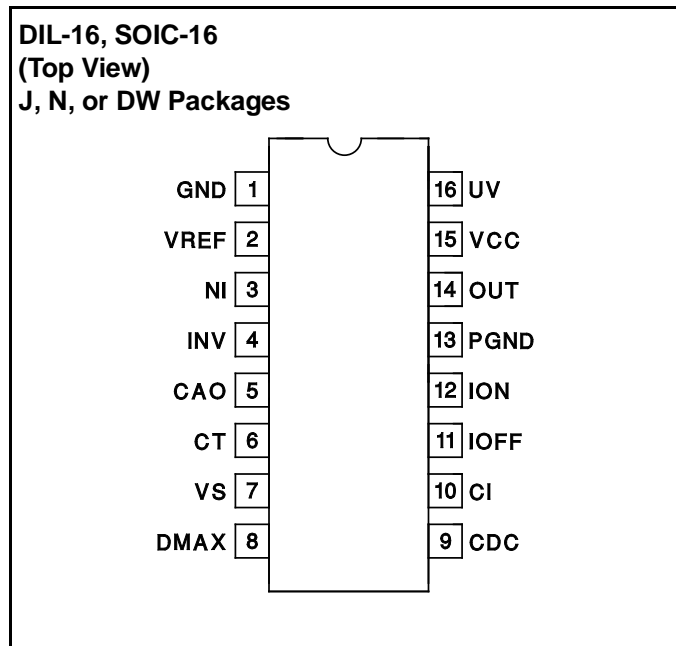

ELECTRICAL CHARACTERISTICS Unless otherwise stated, all specifications are over the junction temperature range of -55°C to +125°C for the UC1848, -40°C to +85°C for the UC2848, and 0°C to +70°C for the UC3848. Test conditions are: VCC = 12V, CT = 400pF, CI = 100pF, IOFF = 100μA, CDC = 100nF, Cvs = 100pF, and lvs = 400μA, TA = TJ.

PARAMETER	TEST CONDITIONS	MIN	TYP	MAX	UNITS
Real Time Current Waveform Synthesizer					
Ion Amplifier					
Offset Voltage		0.95	1	1.05	V
Slew Rate (Note 1)		20	25		V/μs
lib			-2	-20	μA
IOFF Current Mirror					
Input Voltage		0.95	1	1.05	V
Current Gain		0.9	1	1.1	A/A
Current Error Amplifier					
AVOL		60	100		dB
Vio	12V ≤ VCC ≤ 20V, 0V ≤ VCM ≤ 5V			10	mV
lib			-0.5	-3	μA
Voh	Io = -200μA	3	3.3		V
Vol	Io = 200μA		0.3	0.6	V
Source Current	Vo = 1V	1.4	1.6	2.0	mA
GBW Product	f = 200kHz	5	8		MHz
Slew Rate (Note 1)		8	10		V/μs

Note 1: Guaranteed by design.

ELECTRICAL CHARACTERISTICS (cont.):

Unless otherwise stated, all specifications are over the junction temperature range of -55°C to $+125^{\circ}\text{C}$ for the UC1848, -40°C to $+85^{\circ}\text{C}$ for the UC2848, and 0°C to $+70^{\circ}\text{C}$ for the UC3848. Test conditions are: $V_{CC} = 12\text{V}$, $C_T = 400\text{pF}$, $C_I = 100\text{pF}$, $I_{OFF} = 100\mu\text{A}$, $C_{DC} = 100\text{nF}$, $C_{vs} = 100\text{pF}$, and $I_{vs} = 400\mu\text{A}$, $T_A = T_J$.

PARAMETER	TEST CONDITIONS	MIN	TYP	MAX	UNITS
Oscillator					
Frequency	$T_A = 25^{\circ}\text{C}$	240	250	260	kHz
		235		265	kHz
Ramp Amplitude		1.5	1.65	1.8	V
Duty Cycle Clamp					
Max Duty Cycle	$V(D_{MAX}) = 0.75 \cdot V_{REF}$	73.5	76.5	79.5	%
Volt Second Clamp					
Max On Time		900		1100	ns
VCC Comparator					
Turn-on Threshold			13	14	V
Turn-off Threshold		9	10		V
Hysteresis		2.5	3	3.5	V
UV Comparator					
Turn-on Threshold		4.1	4.3	4.5	V
RHYSTERESIS	$V_{uv} = 4.2\text{V}$	77	90	103	k Ω
Reference					
VREF	$T_A = 25^{\circ}\text{C}$ $0 < I_o < 10\text{mA}$, $12 < V_{CC} < 20$	4.95	5	5.05	V
		4.93		5.07	V
Line Regulation	$12 < V_{CC} < 20\text{V}$		4	15	mV
Load Regulation	$0 < I_o < 10\text{mA}$		3	15	mV
Short Circuit Current	$V_{REF} = 0\text{V}$	30	50	70	mA
Output Stage					
Rise & Fall Time (Note 1)	$C_I = 1\text{nF}$		20	45	ns
Output Low Saturation	$I_o = 20\text{mA}$		0.25	0.4	V
	$I_o = 200\text{mA}$		1.2	2.2	V
Output High Saturation	$I_o = -200\text{mA}$		2.0	3.0	V
UVLO Output Low Saturation	$I_o = 20\text{mA}$		0.8	1.2	V
Icc					
I _{START}	$V_{CC} = 12\text{V}$		0.2	0.4	mA
I _{CC} (pre-start)	$V_{CC} = 15\text{V}$, $V(UV) = 0$		0.5	1	mA
I _{CC} (run)			22	26	mA

Note 1: Guaranteed by design.

UNDER VOLTAGE LOCKOUT

The Under Voltage Lockout block diagram is shown in Figure 1. The VCC comparator monitors chip supply voltage. Hysteretic thresholds are set at 13V and 10V to facilitate off-line applications. If the VCC comparator is low, I_{CC} is low (<500 μA) and the output is low.

The UV comparator monitors input line voltage (V_{IN}). A pair of resistors divides the input line to UV. Hysteretic input line thresholds are programmed by R_{v1} and R_{v2}. The

thresholds are

$$V_{IN(on)} = 4.35\text{V} \cdot (1 + R_{v1}/R_{v2'}) \text{ and}$$

$$V_{IN(off)} = 4.35\text{V} \cdot (1 + R_{v1}/R_{v2}) \text{ where}$$

$$R_{v2'} = R_{v2} \parallel 90\text{k}.$$

The resulting hysteresis is

$$V_{IN(hys)} = 4.35\text{V} \cdot R_{v1} / 90\text{k}.$$

When the UV comparator is low, I_{CC} is low (500 μA) and the output is low.

UNDER VOLTAGE LOCKOUT (cont.)

When both the UV and VCC comparators are high, the internal bias circuitry for the rest of the chip is activated. The CDC pin (see discussion on Maximum Duty Cycle Control and Soft Start) and the Output are held low until VREF exceeds the 4.5V threshold of the VREF comparator. When VREF is good, control of the output driver is transferred to

the PWM circuitry and CDC is allowed to charge.

If any of the three UVLO comparators go low, the UVLO latch is set, the output is held low, and CDC is discharged. This state will be maintained until all three comparators are high and the CDC pin is fully discharged.

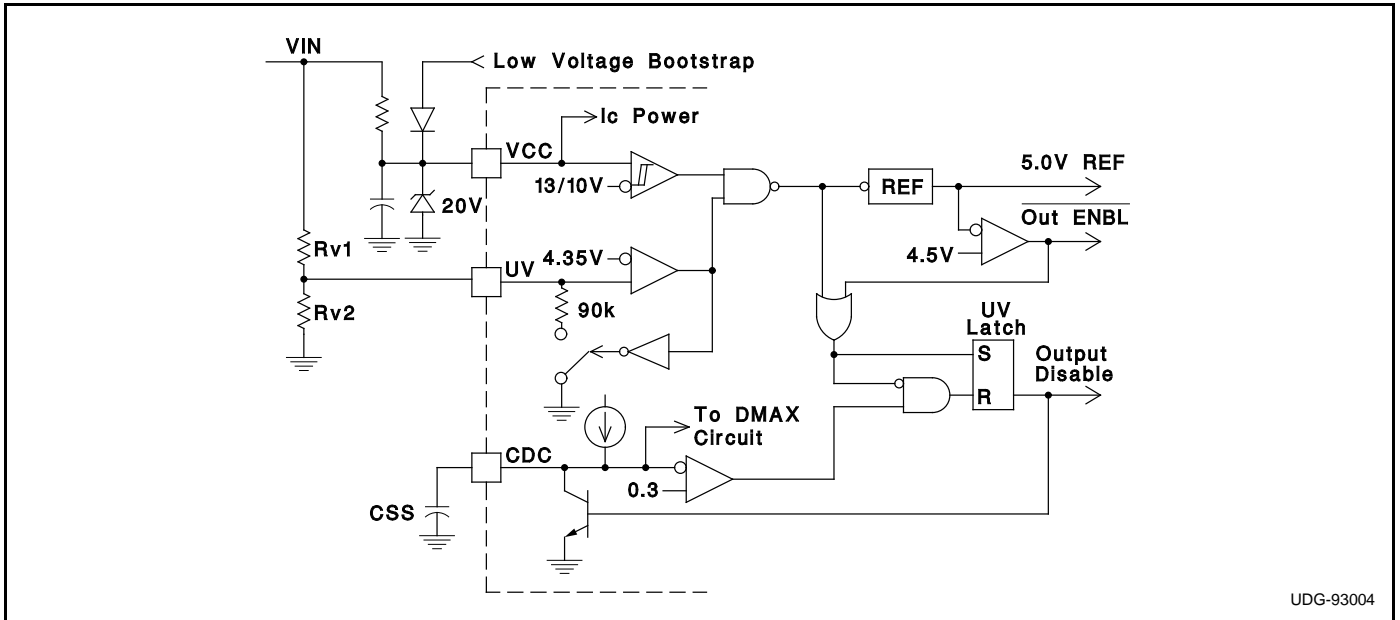

Figure 1: Under Voltage Lockout

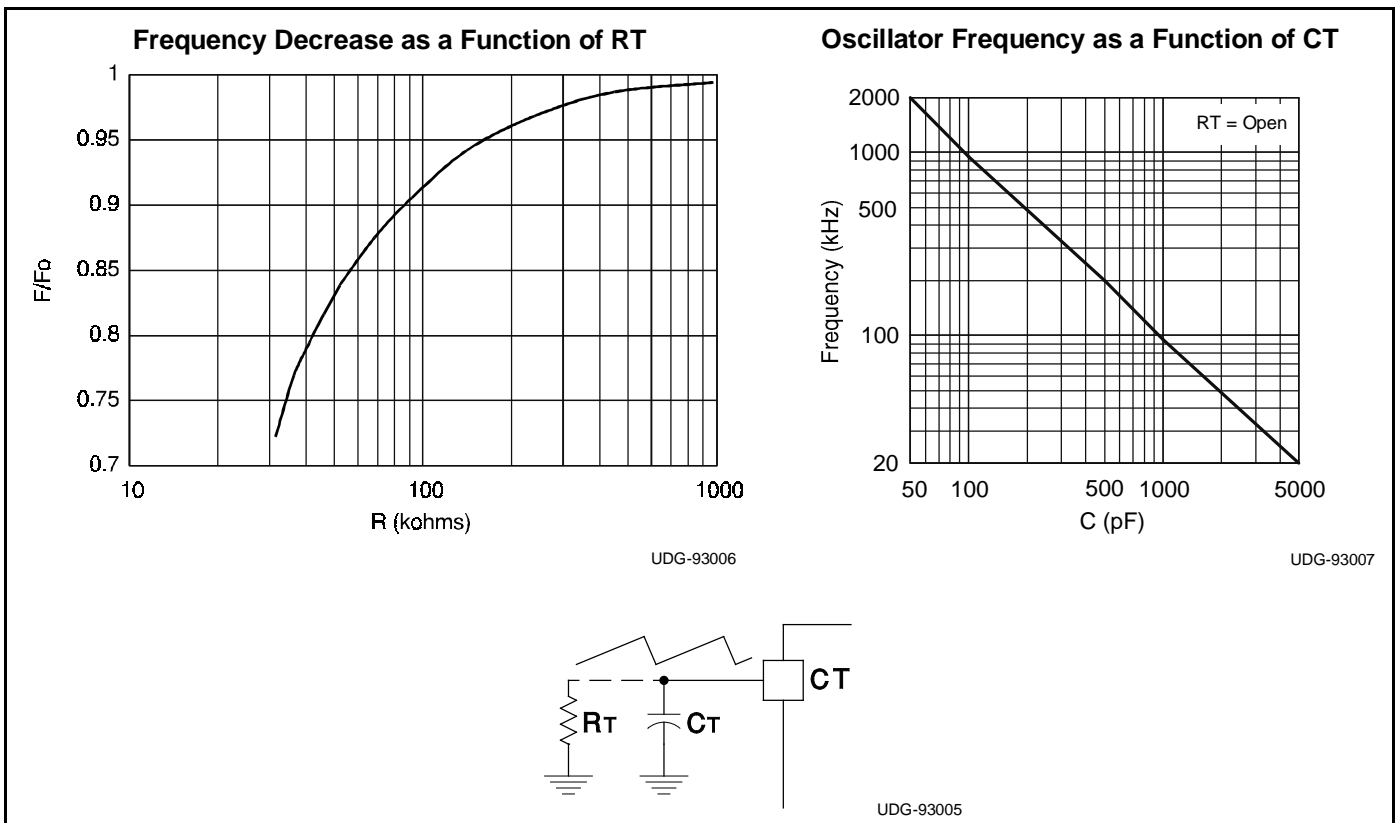

Figure 2: Oscillator Frequency

OSCILLATOR

A capacitor from the CT pin to GND programs oscillator frequency, as shown in Figure 2. Frequency is determined by:

$$F = 1 / (10k \cdot CT).$$

The sawtooth wave shape is generated by a charging current of 200µA and a discharge current of 1800µA. The discharge time of the sawtooth is guaranteed dead time

for the Output Driver. If the maximum duty cycle control is defeated by connecting DMAX to VREF, the maximum duty cycle is limited by the oscillator to 90%. If an adjustment is required, an additional trim resistor RT from CT to Ground can be used to adjust the oscillator frequency. RT should not be less than 40kohms. This will allow up to a 22% decrease in frequency.

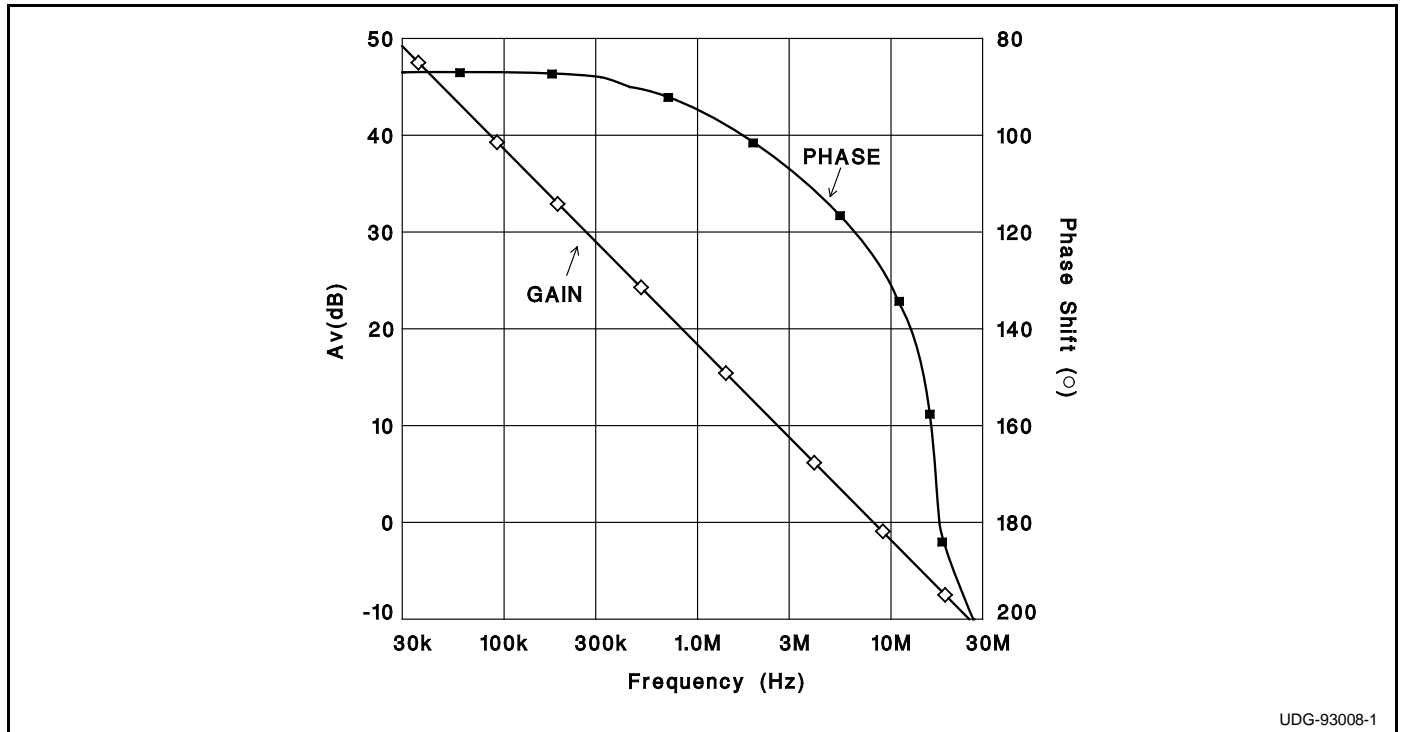

Figure 3: Error Amplifier Gain and Phase Response over Frequency

INDUCTOR CURRENT WAVEFORM SYNTHESIZER

Average current mode control is a very useful technique to control the value of any current within a switching converter. Input current, output inductor current, switch current, diode current or almost any other current can be controlled. In order to implement average current mode control, the value of the current must be explicitly known at all times. To control output inductor current (IL) in a buck derived isolated converter, switch current provides inductor current information, but only during the on time of the switch. During the off time, switch current drops abruptly to zero, but the inductor current actually diminishes with a slope $dIL/dt = -Vo/L$. This down slope must be synthesized in some manner on the primary side to provide the entire inductor current waveform for the control circuit.

The patented Current Waveform Synthesizer (Figure 4) consists of a unidirectional voltage follower which forces the voltage on capacitor CI to follow the on time switch current waveform. A programmable discharge current synthesizes the off time portion of the waveform. ION is

the input to the follower. The discharge current is programmed at IOFF.

The follower has a one volt offset, so that zero current corresponds to one volt at CI. The best utilization of the UC1848 is to translate maximum average inductor current to a 4 volt signal level. Given N and Ns (the turns ratio of the power and current sense transformers), proper scaling of IL to V(CI) requires a sense resistor Rs as calculated from:

$$Rs = 4V \cdot Ns \cdot N / IL(max).$$

Restated, the maximum average inductor current will be limited to:

$$IL(max) = 4V \cdot Ns \cdot N / Rs.$$

IOFF and CI need to be chosen so that the ratio of $dV(CI)/dt$ to dIL/dt is the same during switch off time as on time. Recommended nominal off current is 100µA. This requires

$$CI = (100\mu A \cdot N \cdot Ns \cdot L) / (Rs \cdot Vo(nom))$$

where L is the output inductor value and Vo(nom) is the converter regulated output voltage.

INDUCTOR CURRENT WAVEFORM SYNTHESIZER (cont.)

There are several methods to program IOFF. If accurate average current control is required during short circuit operation, IOFF must track output voltage. The method shown in Figure 4 derives a voltage proportional to $V_{IN} \cdot D$ (Duty Cycle). (In a buck converter, output voltage is proportional to $V_{IN} \cdot D$.) A resistively loaded diode connection to the bootstrap winding yields a square wave whose amplitude is proportional to V_{IN} and is duty cycle modulated by the control circuit. Averaging this waveform with a filter generates a primary side replica of secondary regulated V_o . A single pole filter is shown, but in practice a two or three pole filter provides better transient response. Filtered voltage is converted by ROFF to a current to the IOFF pin to control CI down slope.

If the system is not sensitive to short circuit requirements, Figure 5 shows the simplest method of downslope generation: a single resistor ($R_{OFF} = 40k$) from IOFF to VREF. The discharge current is then $100\mu A$. The disadvantage to this approach is that the synthesizer continues to generate a down slope when the switch is off even dur-

ing short circuit conditions. Actual inductor down slope is closer to zero during a short circuit. The penalty is that the average current is understated by an amount approximately equal to the nominal inductor ripple current. Output short circuit is therefore higher than the designed maximum output current.

A third method of generating IOFF is to add a second winding to the output inductor core (Figure 6). When the power switch is off and inductor current flows in the free wheeling diode, the voltage across the inductor is equal to the output voltage plus the diode drop. This voltage is then transformed by the second winding to the primary side of the converter. The advantages to this approach are its inherent accuracy and bandwidth. Winding the second coil on the output inductor core while maintaining the required isolation makes this a more costly solution. In the example, $R_{OFF} = V_o / 100\mu A$. The $4 \cdot R_{OFF}$ resistor is added to compensate the one volt input level of the IOFF pin. Without this compensation, a minor current foldback behavior will be observed.

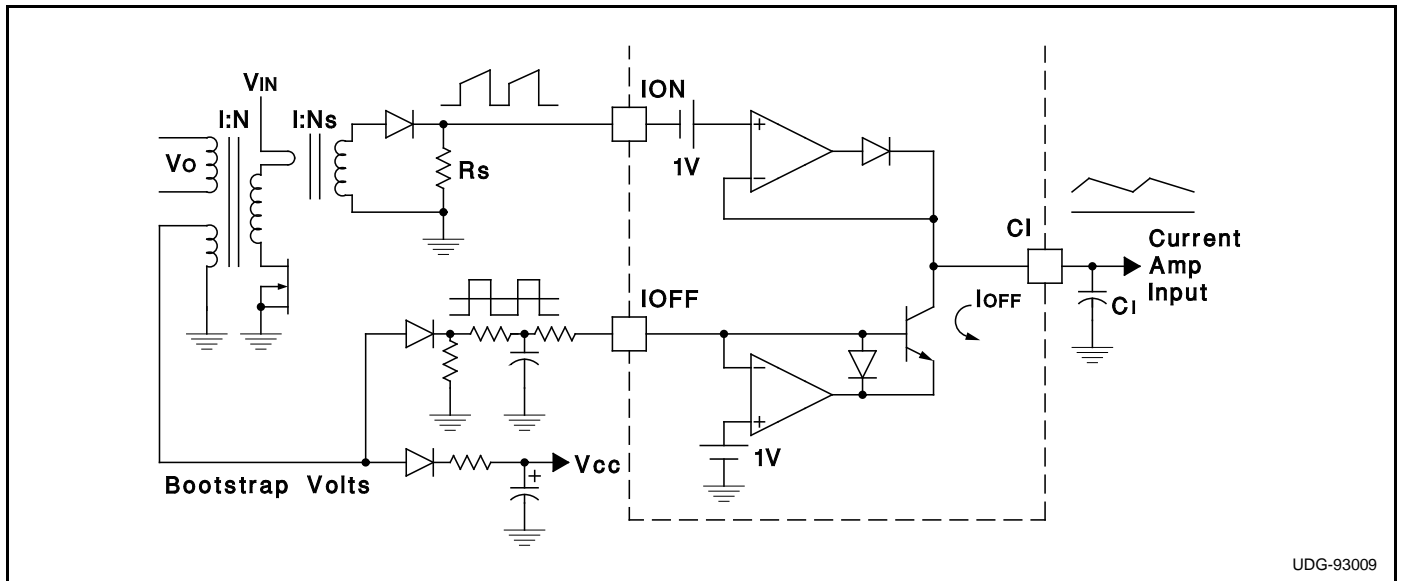

Figure 4: Inductor Current Waveform Synthesizer

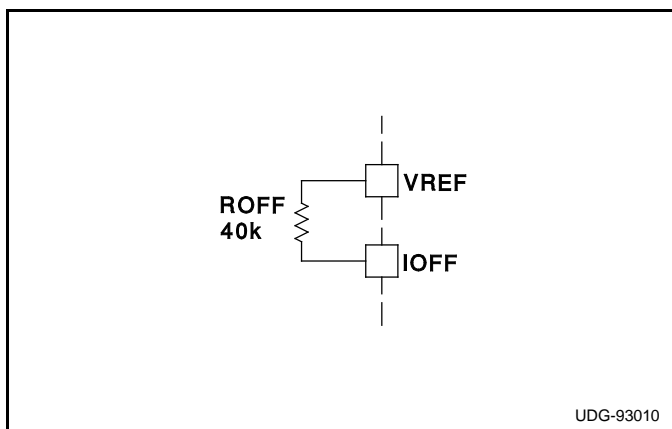

Figure 5: Fixed IOFF

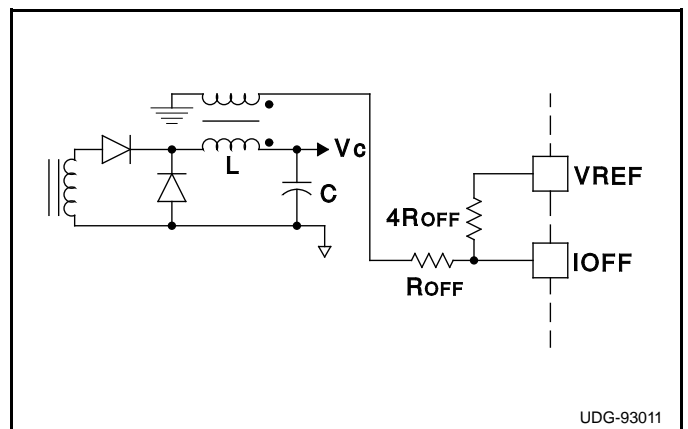

Figure 6: Second Inductor Winding Generation of IOFF

MAXIMUM VOLT-SECOND CIRCUIT

A maximum volt-second product can be programmed by a resistor (R_{vs}) from V_S to V_{IN} and a capacitor (C_{vs}) from V_S to ground (Figure 7). V_S is discharged while the switch is off. When the output turns on, V_S is allowed to charge. Since the threshold of the V_S comparator is much less than V_{IN} , the charging profile at V_s will be essentially linear. If V_S crosses the 4.0V threshold before the PWM turns the output off, the V_S comparator will turn the output off for the remainder of the cycle. The maximum volt-second product is

$$V_{IN} \cdot T_{ON(max)} = 4.0V \cdot R_{vs} \cdot C_{vs}.$$

MAXIMUM DUTY CYCLE AND SOFT START

A patented technique is used to accurately program maximum duty cycle. Programming is accomplished by a divider from V_{REF} to D_{MAX} (Figure 7). The value programmed is:

$$D(max) = R_{d1} / (R_{d1} + R_{d2}).$$

For proper operation, the integrating capacitor, C_{DC} , should be larger than $C_{DC(min)} > T(osc) / 80k$, where $T(osc)$ is the oscillator period. C_{DC} also sets the soft start time constant, so values of C_{DC} larger than minimum may be desired. The soft start time constant is approximately:

$$T(ss) = 20k \cdot C_{DC}.$$

GROUND PLANES

The output driver on the UC1848 is capable of 2A peak currents. Careful layout is essential for correct operation of the chip. A ground plane must be employed (Figure 8). A unique section of the ground plane must be designated for high di/dt currents associated with the output stage. This point is the power ground to which to PGND pin is connected. Power ground can be separated from the rest of the ground plane and connected at a single point, although this is not strictly necessary if the high di/dt paths are well understood and accounted for. V_{CC} should be bypassed directly to power ground with a good high frequency capacitor. The sources of the power MOSFET should connect to power ground as should the return connection for input power to the system and the bulk input capacitor. The output should be clamped with a high current Schottky diode to both V_{CC} and PGND. Nothing else should be connected to power ground.

V_{REF} should be bypassed directly to the signal portion of the ground plane with a good high frequency capacitor. Low esr/esl ceramic 1 μ F capacitors are recommended for both V_{CC} and V_{REF} . The capacitors from CT, CDC, and CI should likewise be connected to the signal ground plane.

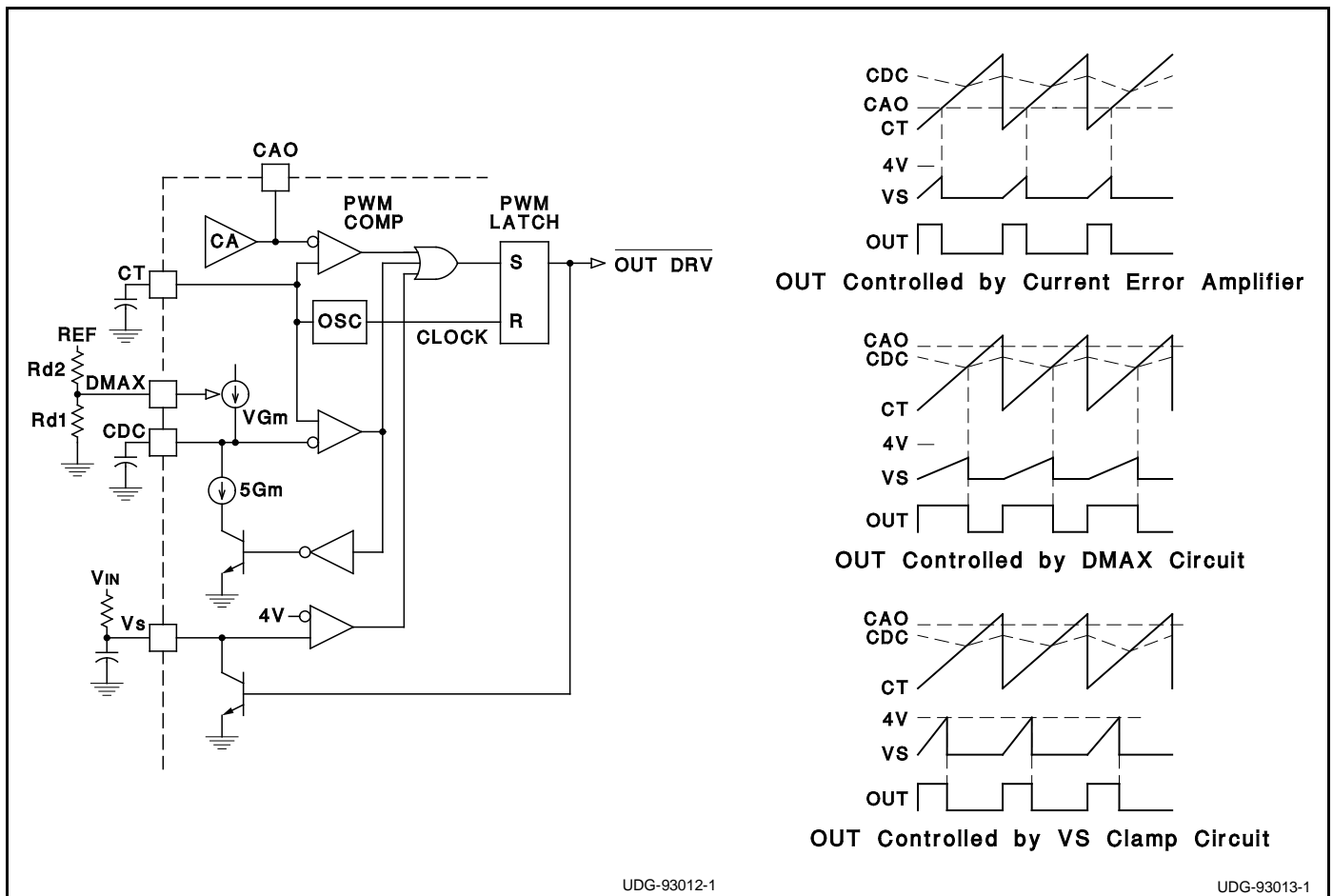
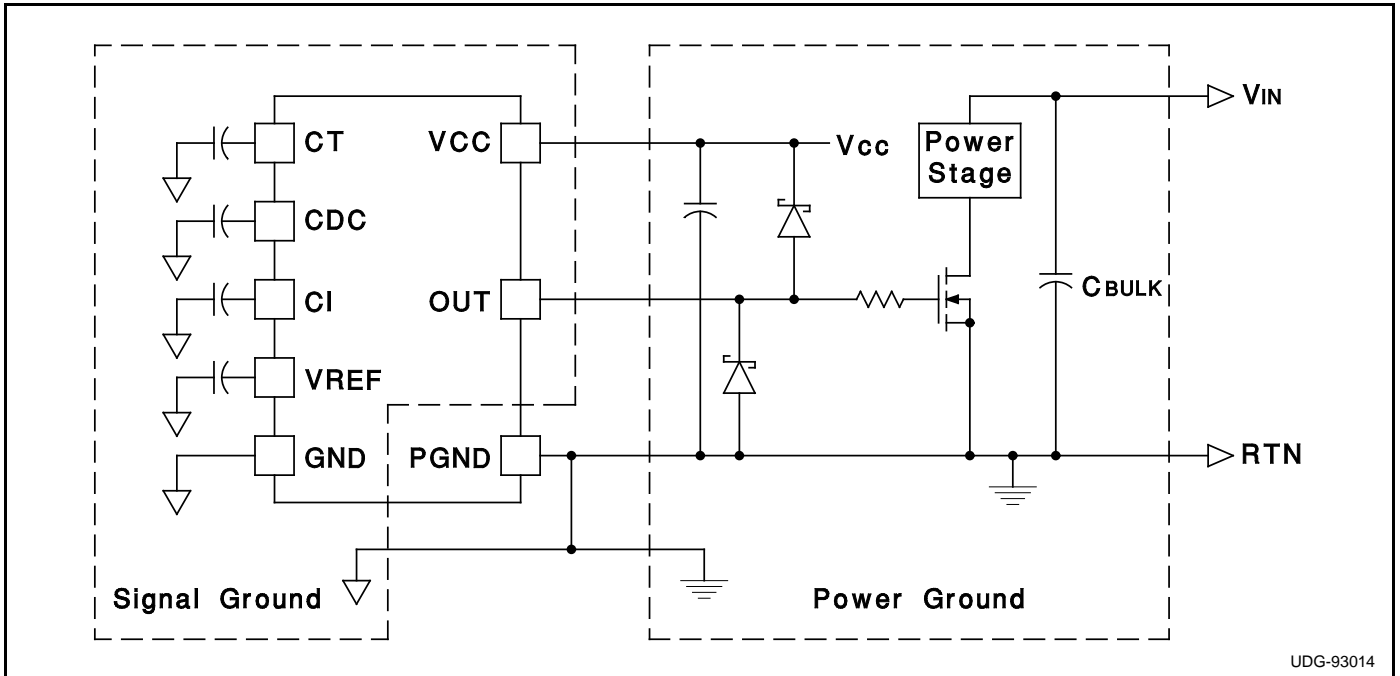
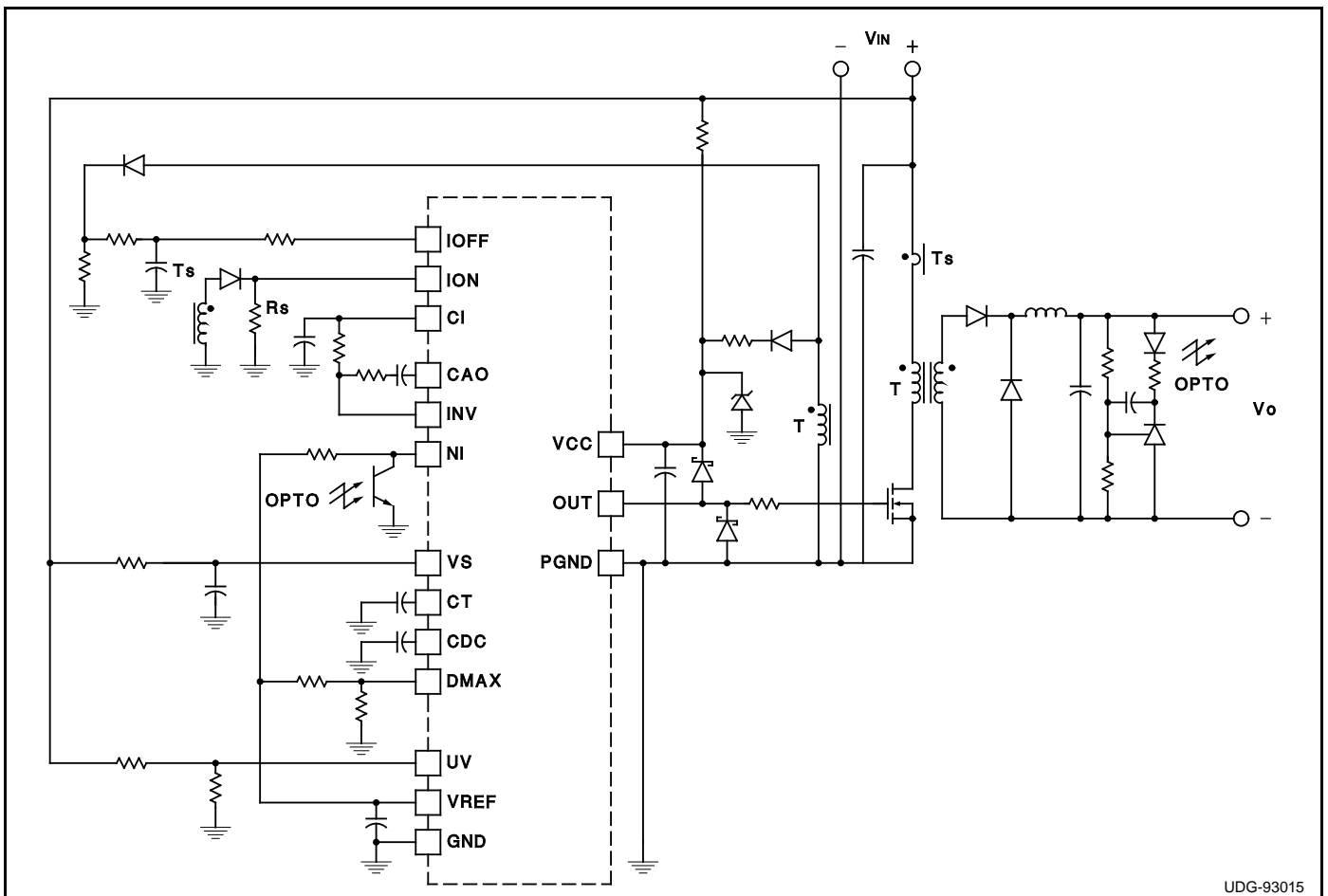

Figure 7: Duty Cycle Control



UDG-93014

Figure 8: Ground Plane Considerations



UDG-93015

Figure 9: Typical Application - An Average Current -Mode Isolated Forward Converter